

# PLAST-O-MATIC<sup>®</sup>

V A L V E S , I N C .

## MODEL LLS

### Liquid Level Switch

### Installation and Operating Instructions

Model LLS liquid level switch is supplied with a 1 ¼" x ¼" NPT TT bushing, which allows the unit to pass through a 1 ¼" NPT female thread, located in the side or top of a tank. Teflon tape is factory applied to the ¼" NPT end of the switch housing, which is threaded into the 1 ¼" x ¼" bushing and tightened to provide a sealed connection. A mark on the top of the 1 ¼" x ¼" bushing indicates the plane of motion of the float.

Horizontal mounting through the side wall of the tank.

- A. The male 1 ¼" NPT thread of the 1 ¼" x ¼" bushing is Teflon taped at the factory. Inspect the taped threads for uniform tape covering. If the Teflon tape has been damaged, remove and replace with new tape.
- B. Insert Model LLS through the 1 ¼" NPT opening in the wall of the tank, thread the 1 ¼" x ¼" bushing into place, and tighten until seal is obtained, as per standard PVC pipe fittings. Tighten additional amount until the mark o points vertically upward. Tighten with strap wrench only. DO NOT use a pipe wrench.
- C. Model LLS is designed to be field replaceable for "donut" sliding float types with ¼" NPT on end of the switch housing tube. Installation is accomplished as follows:
  1. Disconnect the old sliding float switch wires and unthread the unit from the support (e.g. 2" flange, bushing, etc.)
  2. Clean the female threads, apply Teflon tape to the LLS threads as required, and tighten them in place as required to ensure a proper seal.
  3. Move the LLS float through the full travel to ensure float motion is not restricted by adjacent structures. Mark the outside surface of the flange, bushing, etc. to indicate the plane of motion and "up" position of the float.

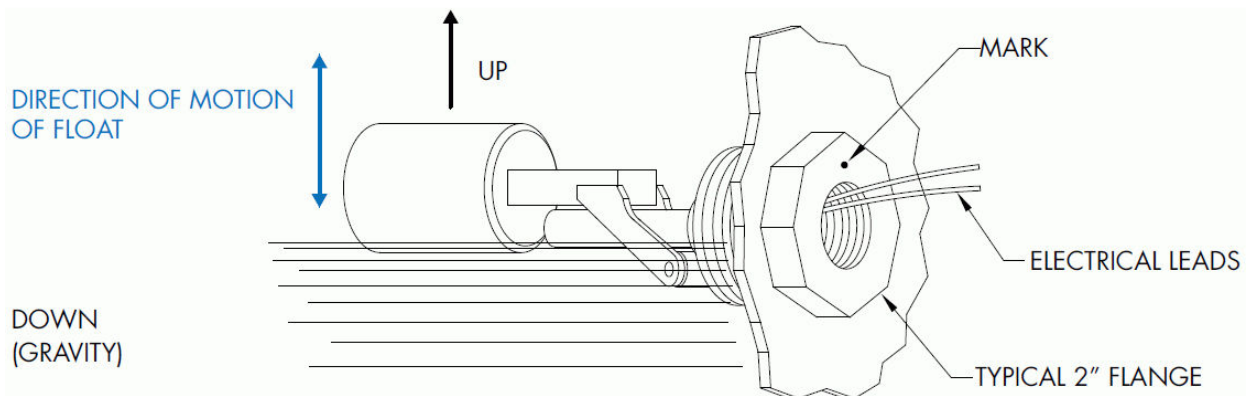

- A. Same as A) on previous page.
- B. Insert Model LLS through the 1 ¼" NPT opening in the top of the tank, thread the 1 ¼" x ¼" bushing into place and tighten it until seal is obtained as per standard PVC pipe fittings. Mark indicates the plane of motion of the float, which may be in any position or a particular position should internal structure interfere with motion of float.
- C. Field replacement of top mounted "donut"-type sliding float level switches is the same as C) on the previous page, except that indexing the plane of motion of the float is not required except when tank internal structure interferes with float motion.

## ELECTRICAL WIRING

Check switch operation with an ohmmeter prior to installing to insure switch is activated when float is moved between stops. NOTE: Switch must be activated and deactivated when float is in a position near but not at stop.

