

SERIES EBVF & TEBVF MULTI-VOLTAGE ELECTRIC ACTUATORS

Installation, Operation & Maintenance Instructions

Damage caused by non-compliance to these instructions will not be covered by our warranty. Read these instructions BEFORE installing or connecting the actuator.

SAFETY INSTRUCTIONS: Electric actuators operate with the use of live electricity. It is recommended that only qualified electricians or people instructed in accordance with electrical engineering, and familiar with local electrical, health and safety directives, be involved in the connection of these actuators. It is strongly recommended that each actuator has its own independent fused system to protect it against the influence of other electrical devices connected to the system.

ELECTRICAL CONNECTORS (DIN Plugs)

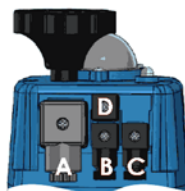

- Connectors**
 A – Power supply
 B – Digital Positioner (Electronic Control Mode)
 C – Position Confirmation
 D – Programming (Factory Use Only)



Warning! BEFORE connecting, ensure the voltage to be applied is within the range shown on the ID label. Do NOT connect a voltage in excess of the intended design or irreparable damage will be caused and will NOT be covered by our warranty.

EBVFs are multi-voltage capable with automatic voltage sensing. All connections are made using the supplied external DIN plugs. The rotation is factory set so under normal circumstances there is no need to remove the cover to connect electrically - in fact removing the cover may invalidate the warranty.

The EBVF has 2 voltage ranges: EBVF-1,-3 and TEBVF-5-7 Series: Accepts voltages from 24-240V AC(1ph) or DC
 EBVF-2,-4 and TEBVF-6-8 Series: Accepts 12V AC (1ph) or DC

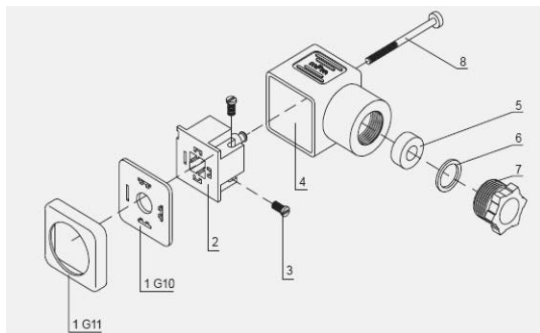

1. Gasket/seal. We use G11
2. Terminal strip
3. Cable securing screws
4. Housing
5. Grommet
6. Washer
7. Gland nut
8. Securing Screw

CABLE SIZE	SMALL CONNECTOR		LARGE CONNECTOR	
	Minimum Diameter	Maximum Diameter	Minimum Diameter	Maximum Diameter
EBVF	5 mm	5 mm	8 mm	10.5 mm

WARNING — Water-tightness: Ensure that the rubber gasket (part 1 above) is correctly installed when securing a DIN plug to the actuator. Failure to do so could allow water ingress - damage caused by this installation error will invalidate any warranty. Do not over-tighten the securing screw (part 8) when assembling. Note that the lip on the rubber gasket covers the edges of the female DIN connector that you are wiring, and not the male DIN connector on the actuator.

WIRING DIAGRAMS FOR ON-OFF VERSION

AC (1ph) or DC SUPPLY – WIRING ON/OFF OR FAIL SAFE ACTUATORS

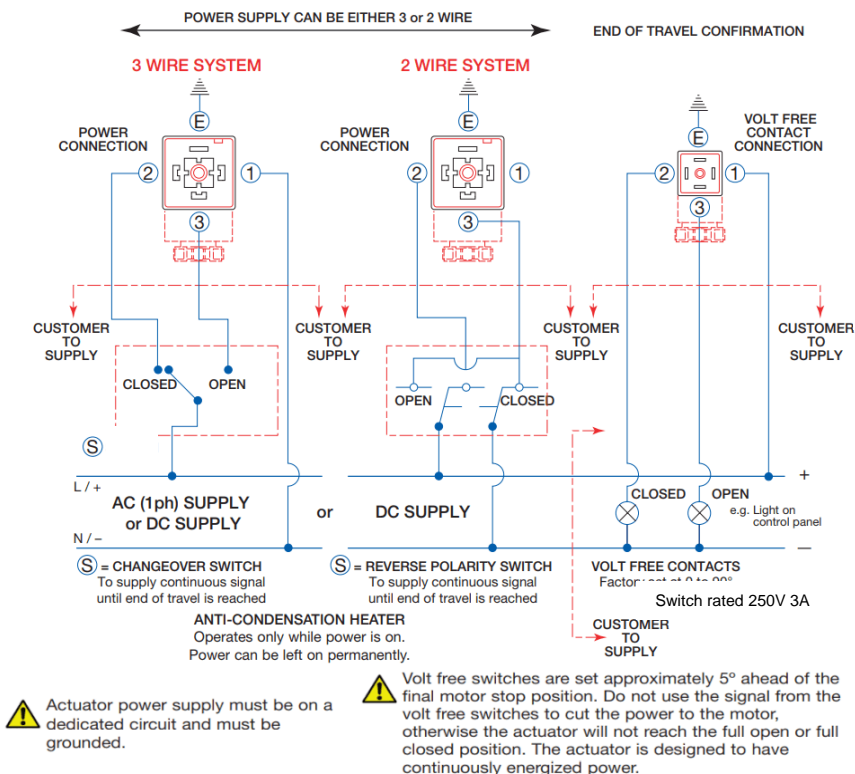

On receipt of a continuous power signal, the motor runs and via a planetary gearbox system, rotates the output shaft. The motor is stopped by internal cams, fitted to the output shaft, striking micro-switches which cuts power to the motor. When a subsequent continuous signal is received, the motor will turn in the opposite direction, reversing the direction of rotation of the output shaft.

WIRING DIAGRAM FOR MODULATION

AC (1ph) or DC SUPPLY – WIRING FOR MODULATING ACTUATORS

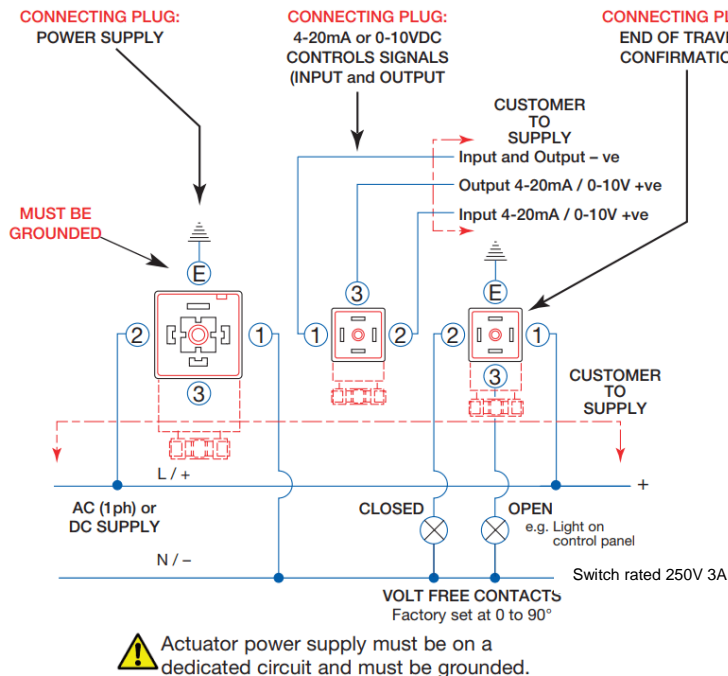

FUNCTION: MODULATING VERSION:

Power open, power close-actuator movement controlled by input signal ((4-20mA or 0-10VDC).

Standard operation: 4mA or 0V=actuator closed, 20mA or 10V=actuator open (can be reversed).

Standard operation: Actuator closes on loss of control signal, stays put on loss of main power.

Output signal (in same format as supply signal) provided as standard.

The control signal connecting plug is rotated by 180° to avoid connecting the end of travel confirmation plug in the control plug position by mistake – this erroneous connection would damage the positioner beyond repair, and this is not covered by our warranty.

Note: FAIL SAFE “OPEN” WITH MODULATING OPTION

If an EBVF actuator is ordered in the FAIL OPEN configuration and the actuator contains both the BATTERY BACKUP, and the MODULATING kits, the actuator will move to the FAIL OPEN position upon loss of main POWER. If you require that the actuator move to the FAIL OPEN position upon loss of CONTROL SIGNAL, then it will be configured such that 4 mA or 0VDC) CLOSE the valve and 20 mA (or 10 VDC) OPEN the valve, then the actuator will CLOSE the valve upon loss of CONTROL SIGNAL. Upon loss of BOTH POWER and CONTROL SIGNAL, the battery will take over and the actuator will move to the OPEN position.

Emergency Manual Override

All EBVF electric actuators are provided with a declutchable manual override to allow manual operation should power not be available. There are 2 marked, selectable positions:

MAN for manual operation and AUTO for automatic operation.

- **Do NOT attempt to operate the manual override operator without first selecting MAN** using the manual override selector lever otherwise irreparable damage will be caused to the actuator gearbox. Damage so caused is NOT covered by our warranty.
- **Do NOT remove the manual override selector lever retaining screw** as this will allow the internal parts to become loose and will cause irreparable damage to the actuator gearbox. Damage so caused is NOT covered by our warranty.



Operating procedure for manual override:

If the actuator is rotated beyond the open and closed logos taking it outside the working areas (0-180°), and left outside the working area when returned to AUTO, malfunction may occur - see following pages for detailed information.



Operating the manual override will cause the LED status light to flash -- see following pages for details.

Selecting emergency manual operation: Using the manual override selector lever, select MAN. Do not force the lever the actuator will be damaged; this is not covered by our warranty. There are different situations from which MAN can be selected that each receive different responses from the EBVF actuator, which are outlined on the next page...

Series EBVF Status Light Functions

ON/OFF ACTUATOR	ACTUATOR OPERATIONAL STATUS (200 msec/block)
No power detected	
In position open	
In position close	
Opening	
Closing	
Torque limiter engaged, moving from close to open	
Torque limiter engaged, moving from open to close	
Actuator in MANUAL mode	
Multiple concurrent signals	
FAIL SAFE ACTUATOR	ACTUATOR OPERATIONAL STATUS
No power detected	
In position open	
In position close	
Opening	
Closing	
Torque limiter engaged, moving from close to open	
Torque limiter engaged, moving from open to close	
Actuator in MANUAL mode	
Multiple concurrent signals	
Actuator without power, working with the NO system. Max.3 min., led off	
Actuator without power, working with the NC system. Max.3 min., led off	
Battery protection. Danger, the battery needs recharging. Fail Safe blocked	
MODULATING ACTUATOR	ACTUATOR OPERATIONAL STATUS
No power detected	
Actuation feedback complete	
Opening	
Closing	
Auto adjusting configuration / reset	
Torque limiter engaged, moving from close to open	
Torque limiter engaged, moving from open to close	
Unrecognized modulation signal. Actuator stopped.	
Actuator in MANUAL mode	
Waiting for modulation signal	

ANTI-CONDENSATION HEATER: The EBVF actuator has a thermostatically controlled anti-condensation heater that maintains the internal housing at approx. 30°C. The heater is activated whenever mains power is connected to the actuator. We strongly recommend that power remains ON at all times to protect the actuator from the damaging effects of condensation. Damage caused by condensation is not covered by our warranty.

ELECTRONIC TORQUE LIMITER: All EBVF electric actuators are protected against the possible mechanical drive train damage caused by a valve blockage or jam. This protection is provided by an electronic torque limiter (ETL) in an internal micro-chip that is programmed to constantly measure and compare the motor load against a factory set maximum.

As torque is directly proportional to motor load, as the torque increases the motor load increases. The ETL closely monitors the rate of increase in motor load as the valve starts to come to rest at the jam, and as this occurs the motor load exceeds the factory set maximum and the ETL is activated, instantly cutting the power supply to the motor.

As the valve nears the jam point, the planetary gears are being driven hard in the direction of the jam, and at the jam point, they too are physically jammed. This would make selecting MAN to put the actuator in manual mode to assist in clearing the jam impossible - to eliminate this difficulty, the ETL, a few seconds after cutting the power to the motor, moves the actuator a few degrees in the opposite direction of the jam, to relax the gears.



Activating the electronic torque limiter triggers a change in the LED status light (see previous page) sequence. The EBVF allows the user to apply a reversing command signal to the actuator (in the opposite direction to the jam eg: if the actuator was closing, an open signal will be accepted) to power the actuator away from the jam. In many cases, this allows the flowing media to help clear the jam as this can be done several times, and prevent the user from having to shut the system down to dismantle the valve to clear the jam.



Sending a reversing signal will change the LED display (see previous page). When the actuator is subsequently sent back in the direction of the original jam, if it has not cleared the electronic torque limiter will be activated again and the LED will change accordingly.

Simple diagnostics: If the actuator will not respond to a command signal and the LED is flashing on-off, the electronic torque limiter has activated indicating that the torque required to turn the valve has exceeded the maximum output of the actuator. The user instantly knows that there is a problem with the valve, not the actuator.

Mounting Instructions: 2-Way Valves • 3/8" through 2"

(Separate Instructions included in carton for 3-Way Valves and larger sizes)

NOTE ALUMINUM ADAPTER MUST BE ADDED FOR 3/8" THRU 1" SIZES

PLASTIC SPACER MUST BE ADDED FOR 1¼" THRU 2" SIZES

- 1) Move the valve to the open position.
- 2) The actuator package has (2) sets of hardware with it.
 - a) 1 set is for 3/8" thru 1" ball valves (MK-037-100) and the other set is for 1-1/4" thru 2" ball valves (MK-125-200).
 - b) Select the proper kit and the other can be saved or discarded.
- 3) When installing the actuator, which is shipped to you in the "Open" position, make certain the ball valve is in the open position.
- 4) The following applies to kit MK-037-100 only. If you are using kit MK-125-200 skip to step 8 below.
- 5) **The kit MK-037-100** has a small aluminum cube shaped piece. This adaptor is used to adapt the valve stem to fit into the actuator (female) coupling. Mount the cutout on that aluminum adaptor onto the valve stem. To assure that the adaptor is correctly installed, when the valve (in the open position) is installed into the female coupling on the actuator, with the flow direction on the valve inline with the position indicator on the top of the actuator, the coupling should fit snug into the female coupling. If it is a sloppy fit, then rotate the aluminum adaptor 90° (without rotating the valve stem) and you'll see that it fits snug. This is the correct orientation of the adaptor.
- 6) Notice on the PVC mount block on the bottom of the actuator, the block has (6) threaded holes. Only 1 set will fit the particular valve you're installing. For the MK-037-100 kit you have (2) sets of studs. The bag is marked which valve(s) to use the studs for. Depending on which valve you are installing, select the correct studs and install them (2) into the PVC mount block. For 3/8" thru 1/2" valves use the inner most threaded holes. For the 3/4" and 1" valves use the center pair of threaded holes. Use of a thread locking fluid such as Loctite threadlocker is recommended.
- 7) **SPACERS.** The MK-037-100 kit has (2) sets of spacers. Select the set for your valve. Notice the bags are marked. Install the spacers onto the studs, then install the valve onto the studs, and finally install and tighten the nuts onto the studs.
- 8) **The kit MK-125-200** has (2) studs, (2) spacers, (2) nuts.
- 9) Notice on the PVC mount block on the bottom of the actuator, the block has (6) threaded holes. Only 1 set will fit the particular valve you're installing.



- 10) For kit MK-125-200, thread the (2) studs into the outer set of threaded holes. Use of a thread locking fluid such as Loctite threadlocker is recommended.
 - 11) The kit MK-125-200 has (2) spacers. Install these onto the studs then install the valve, then install and tighten the nuts.
- 12) WIRING THE ACTUATOR (With no failsafe or modulating kit, i.e. a simple on/off actuator)**
- 13) Follow the wiring diagram on the actuator label. Note that the actuator labeled 24-240 AC or DC volts will accept any voltage between those limits in either AC or DC form. Any actuator labeled 12V AC or DC will likewise accept any voltage within those limits either AC or DC.
 - 14) The main actuating voltage is wired into the large grey DIN connector. The small black connector can be used to power external position indication per the wiring diagram

Mounting Series TEBVF Electric Actuator to the ball valve Instructions for 3-way valves • 3/8" through 2"

1. The valve stem must be set "in-line" with the (2) upper ports, see photo at right. Notice the orientation of the flats on the stem.
- 
2. The actuator package has (2) sets of hardware with it.
 - a. 1 set is for 3/8" thru 1" ball valves (MKT-037-100) and the other set is for 1-1/4" thru 2" ball valves (MK-125-200).
 - b. Select the proper kit and the other can be saved or discarded.
 3. When installing the actuator, which is shipped to you in the "Open" position, make certain the ball valve is in the position outlined in step 1 above.
 4. The following applies to kit MKT-037-100 only. If you are using kit MK-125-200 skip to step 8 below.
 5. **The kit MKT-037-100** has a small aluminum cube shaped piece. This adaptor is used to adapt the valve stem to fit into the actuator (female) coupling. Mount the cutout on that aluminum adaptor onto the valve stem. To assure that the adaptor is correctly installed, when the valve (in the position described in step 1 above) is installed into the female coupling on the actuator, with the flow direction on the valve inline with the position indicator on the top of the actuator, the coupling should fit snug into the female coupling. If it is a sloppy fit, then rotate the aluminum adaptor 90° on the valve stem (without rotating the valve stem) and you'll see that it fits snug. This is the correct orientation of the adaptor. (See photo on reverse)
 6. Notice on the PVC mount block on the bottom of the actuator, the block has (6) threaded holes (3 "sets" of holes). Only 1 set will fit the particular valve you're installing. For the MKT-037-100 kit you have (3) sets of studs. The bag is marked which valve(s) to use the studs for. Depending on which valve you are installing, select the correct studs and install them (2) into the PVC mount block. For 3/8" thru 1/2" valves use the inner most threaded holes. For the 3/4" and 1" valve use the center pair of threaded holes. Use of a thread locking fluid such as Loctite threadlocker is recommended.
 7. **SPACERS.** The MKT-037-100 kit has (2) sets of spacers. Select the set for your valve. Notice the bags are marked. Install the spacers onto the studs, then install the valve onto the studs, and finally install and tighten the nuts onto the studs.
 8. **The kit MK-125-200** has (2) studs, (2) spacers, (2) nuts.
 9. Notice on the PVC mount block on the bottom of the actuator, the block has (6) threaded holes (3 "sets" of holes). Only 1 set will fit the particular valve you're installing.
 10. For kit MK-125-200, thread the (2) studs into the outer set of threaded holes. Use of a thread locking fluid such as Loctite threadlocker is recommended.
 11. The kit MK-125-200 has (2) spacers. Install these onto the studs then install the valve, then install and tighten the nuts.

WIRING THE ACTUATOR (With no failsafe or modulating kit, i.e. a simple on/off actuator)

Note: Wiring must be done by a qualified electrician, in accordance with all national and local codes.

1. Follow the wiring diagram on the actuator label. Note that the actuator labeled 24-240 AC or DC volts will accept any voltage between those limits in either AC or DC form. Any actuator labeled 12 volt AC or DC will likewise accept any voltage within those limits either AC or DC.
2. The main actuating voltage is wired into the large grey DIN connector. The small black connector can be used to power external position indication per the wiring diagram

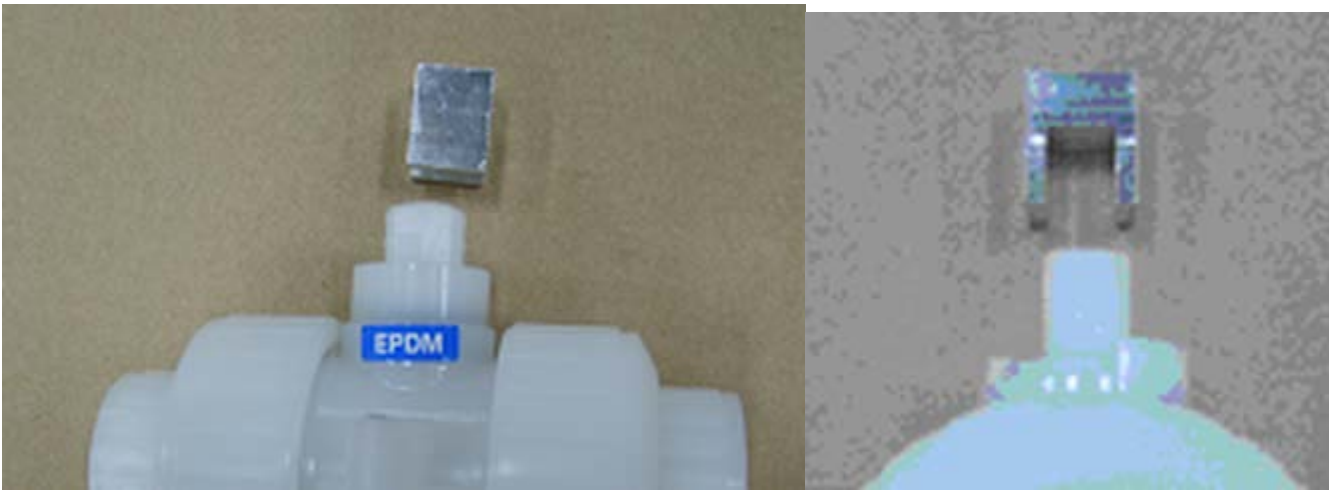

The kit MKT-037-100 has a small aluminum cube shaped piece. This adaptor is used to adapt the valve stem to fit into the actuator (female) coupling. Mount the cutout on that aluminum adaptor onto the valve stem. To assure that the adaptor is correctly installed, when the valve (in the position described in step 1 above) is installed into the female coupling on the actuator, with the flow direction on the valve inline with the position indicator on the top of the actuator, the coupling should fit snug into the female coupling. If it is a sloppy fit, then rotate the aluminum adaptor 90° on the valve stem (without rotating the valve stem) and you'll see that it fits snug. This is the correct orientation of the adaptor.

* * * * *

MAINTENANCE INSTRUCTIONS: The EBVF actuators are generally maintenance free. There are no internal parts that require maintenance. The gearbox is lubricated for life when built at the factory. The housing may be cleaned with a cloth covered in warm soapy water to keep it clean. Do not use solvents.



DO NOT PRESSURE WASH. Pressure washing will invalidate any warranty.

FAILSAFE & DPS ACTUATORS

Full details and instructions are supplied with these options.

Failsafe System (Battery Spring Return): This system simply stores power in a re-chargeable industrial battery pack that instantly discharges when mains power is interrupted. During normal operation the actuator functions as an on-off actuator and simultaneously trickle charges the battery pack to maintain it at full charge. A short re-charge time is required following each discharge to replace the power used. The main advantage of this system is it is far less expensive than a true mechanical spring return system as the actuator size remains the same, as there are no springs to compress.

FAIL-SAFE ACTUATOR NOTE: When ordered as a fail-safe actuator, the battery is NOT charged at the factory because subsequent discharge in storage will shorten the battery life. The battery must be charged 36 hours to acquire full charge. When the actuator is powered on, the battery will automatically charge.

DPS Control System (Digital Positioning System): This system provides modulating control whereby the movement of the actuator is totally controlled by an input signal (either 4-20mA or 0-10VDC), which is set at the factory in accordance with the purchase order, the degree of movement of the actuator being proportional to the change in the input signal. The system is digital and constantly compares the position of the actuator output shaft relative to the input signal, and automatically adjusts the actuator position should the actuator position and the input signal not be equal. A feedback signal is provided as standard.