

PS SOLENOID VALVE SEAL KIT

- *Before disassembly, relieve pressure and drain fluid from the valve and piping to be opened. Take proper precautions to protect people and equipment from any residual liquid.*
- *Disassemble the valve in a clean environment. Prevent any dirt, grit, or fiber from getting onto the sealing surfaces or into the moving parts. Do not scratch or damage plastic parts.*
- *A non-scratching probe such as an orangewood stick or ball end dental pick (burnisher) should be used to remove and install O-rings.*
- *Pipe wrenches and vises are not recommended for plastic valves.*
- *Refer to the valve instruction sheet for installation to piping.*

Caution: Do not unscrew any part of the seal kit during assembly. Any change in length will affect valve performance.

1. Remove the cap nut and coil.
2. Unscrew the union nut, pull off the core tube assembly.
3. Remove the old seal kit assembly.
4. For PVC valves, remove the sleeve, replace the sleeve O-ring, and reinstall the sleeve.
5. Install the new seal kit assembly. Make sure the rubber parts are lightly lubricated, and not pinched, rolled, or out of position. (use a lubricant compatible with the elastomer)
6. Align the tabs on the threaded body with the slots on the core tube assembly. With the union nut in place but raised, press the core tube assembly down on the body by hand. Tighten the union nut.
7. Replace the coil and cap nut. *If the valve buzzes, repeat steps 5 and 6. Be careful to align tabs and press down flush.*
8. Align the tabs on the threaded body with the slots on the core tube assembly. With the union nut in place but raised, press the core tube assembly down on the body by hand. Tighten the union nut.
9. Replace the coil and cap nut. *If the valve buzzes, repeat steps 5 and 6. Be careful to align tabs and press down flush.*
10. Remove the four hex head screws from the threaded body. Open the valve and replace the rolling diaphragm and retainer. Replace the small O-ring. Reassemble, and tighten the screws to approximately 15 inch-pounds.

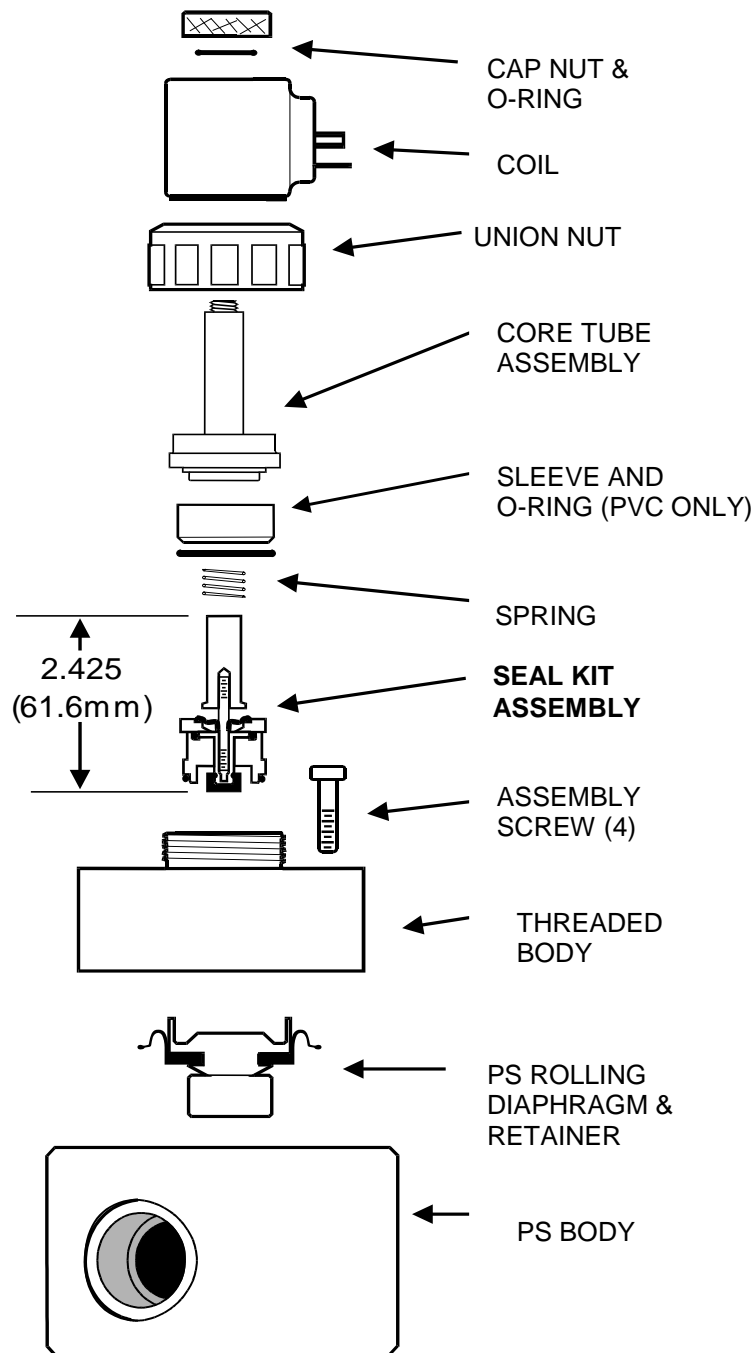

NEED HELP?
CALL 973-256-3000 FOR TECHNICAL SUPPORT