

MARKET Pet Care Products

PRODUCT(S) Series VPA010SV Metering Pump

REQUIREMENT To provide a method to accurately and repeatedly fill containers with liquids in varying viscosities and volumes.

PROCESS FLUID(S) Pet Shampoo, Flea Dip, etc.

INLET PRESSURE/TEMPERATURE Suction / 72°F

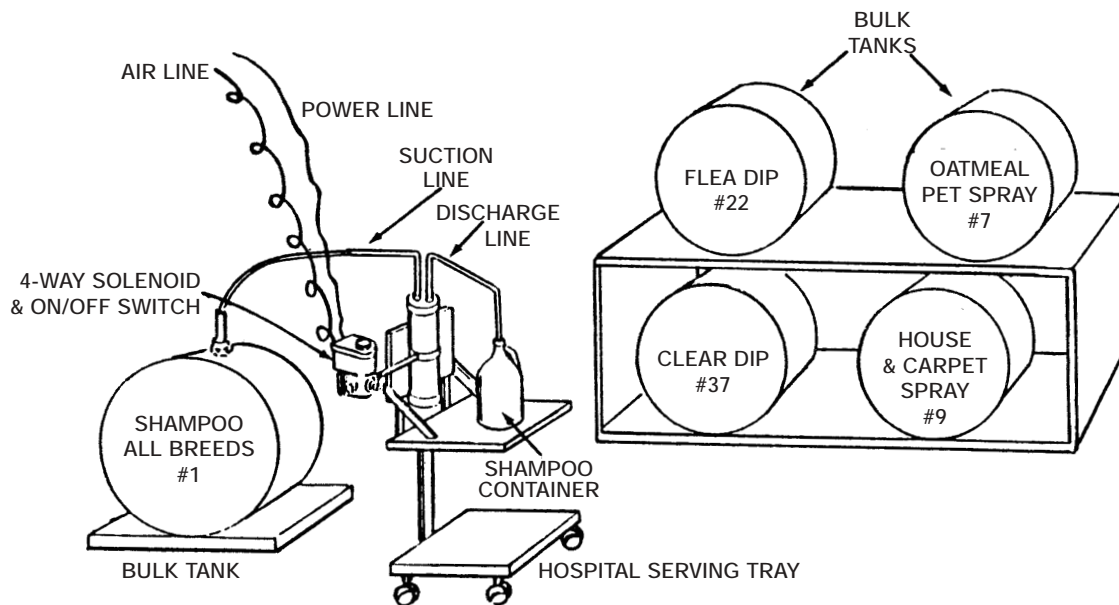

A national pet care products manufacturer required a method to increase productivity and safety in their filling process. Pet care liquids, such as shampoo and flea dip, have different viscosities and are sold in a variety of different size containers. The Plast-O-Matic Series VPA Metering Pump was selected not only for its accuracy of repeatability of 1/2 of 1%, but also for its ability to be adjusted down to 20% of the total pump volume, thereby

allowing one pump to fill various size containers. A reinforced thick wall hose was specified for the suction line which attached to a rigid PVC pipe leading into the tanks. This enabled the pump to be mounted to a mobile hospital serving table that is adjusted to the proper height of the tank and rolled to the various products, thereby creating a mobile filling station.

NOTE: Bulletins are intended only to show possible applications of Plast-O-Matic products and are not design recommendations for a system or its safety. See statement of limitations in front of manual.