

New!

Series "PRU" Ultra-Pure Pressure Regulators All-PTFE Internal Design

PTFE, Kynar® PVDF or Natural Polypropylene Valve Bodies



Features:

- All internal wetted components are chemically inert PTFE for safeguarding media purity.
- Unique convoluted PTFE diaphragm senses downstream pressure and isolates liquid from spring.
- Set pressure range from 5 to 100 PSI.
- Rugged construction with allowable inlet pressure to 120 PSI (8.3 bar).
- PTFE shaft assures smooth, non-sticking operation.
- PTFE, Kynar PVDF or Natural Polypropylene bodies available with flare, socket or NPT connections; Kynar PVDF and Natural Polypropylene also available with spigot connections.

Description:

Designed for ultra-pure water and chemicals, this pressure regulator uses isolated spring force to control downstream pressure.

This regulator should be set while in a flowing condition. Plast-O-Matic uses 1 GPM (3.8 LPM) as a reference. The PRU will handle inlet pressure up to 120 psi and the downstream pressure can be set from 5 to 100 psi.

The design of the PRU features a convoluted PTFE diaphragm that acts upon a PTFE shaft. The tapered end of the shaft is extended through an orifice. Process pressure from the outlet is applied to one side of the diaphragm; spring pressure is applied to the other. The

spring force is adjusted while in the flowing condition to "set" the regulator. The flow path is open, eliminating dead-legs and crevices.

Material of Construction:

Standard body materials are PTFE, Natural Polypropylene, and Kynar® PVDF. Seal and shaft materials are PTFE. The spring housing and adjusting screw (non-wetted) are natural polypropylene. These could be constructed of other materials; consult factory. The springs are stainless steel. Standard connections for polypropylene and PVDF bodies are socket, flare, and spigot. Standard connections for PTFE are threaded and flare. Flanges and other custom connections are available.



PLAST-O-MATIC VALVES, INC.

1384 Pompton Avenue, Cedar Grove, New Jersey 07009-1095
(973) 256-3000 • Fax (973) 256-4745 • www.plastomatic.com

ULTRA-PURE PTFE PRESSURE REGULATORS

Operation:

Series PRU pressure regulators prevent downstream pressure from exceeding the desired set pressure. An isolated spring holds the valve in the open position. When outlet pressure rises near the set point (determined by the spring force), the regulator will begin to close, keeping the downstream pressure from exceeding the set pressure. As equipment or valves downstream of the regulator begin to open and demand flow, the downstream pressure drops below the set point, so the regulator will open.

Because of the high purity, high flow design of Series PRU, it is not designed to close completely. In a "no-flow" condition, outlet pressure will equalize to inlet pressure.

Performance:

Chart shows typical lab tested performance of 1" Regulators Flow Capacity (GPM) versus Outlet Pressure (PSI).

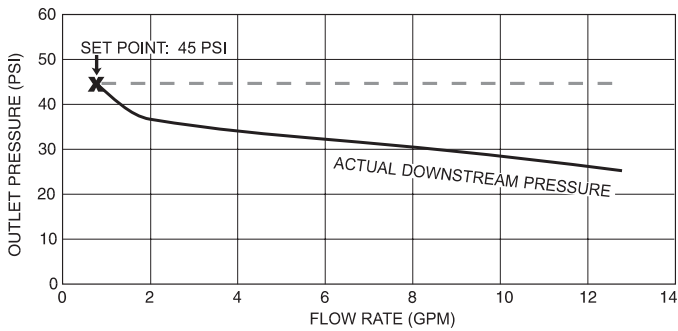

Droop is the difference between the pressure regulator set pressure and the actual downstream pressure at a higher flow. The chart above identifies the high flow capacities and the low pressure droop of Plast-O-Matic regulators which result in their greater sensitivity, finer adjustability and superior accuracy. The dashed line in the chart above represents the "theoretically perfect" pressure regulator; i.e., no droop regardless of flow rate.

Kynar® is a registered trademark of Atofina.
True Blue is a trademark of Plast-O-Matic Valves, Inc. © 2000-2002 Plast-O-Matic Valves, Inc.

Dimensions:

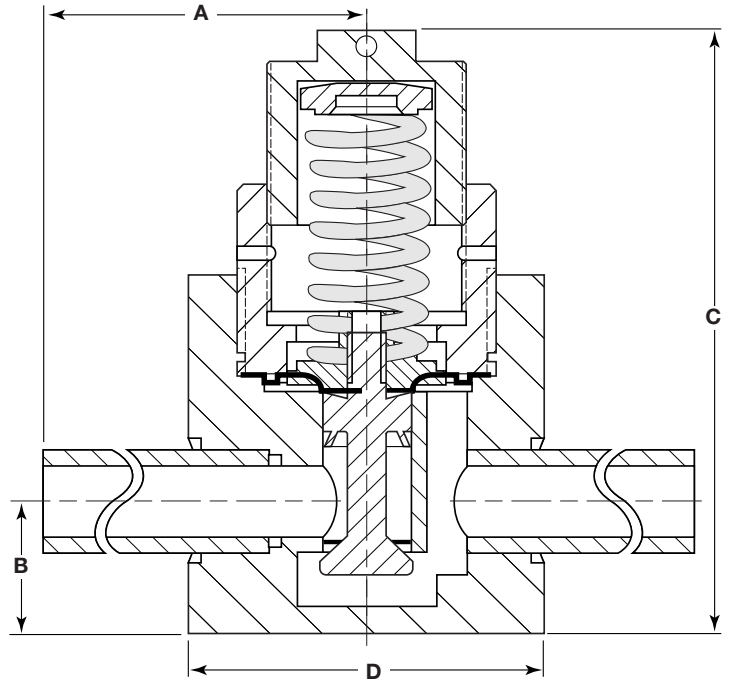

PIPE SIZE	A (typical)		B (max.)		C		D	
	in.	mm.	in.	mm.	in.	mm.	in.	mm.
3/4"	4.25	104.1	2.5	189.8	8.75	46.5	4.50	100.2
1"*	4.25	104.1	2.5	189.8	8.75	46.5	4.50	100.2

* For 1/4", 1/2" dimensions, consult factory.

Model Numbers & Body Type:

PRU 100 T - FR - PF				
Series	Size	Seal Material	Fitting	Body Material
	3/4" - 075 1" - 100	T - PTFE	FR - Flare SP - Spigot S - Socket T - Threaded	PF - Kynar® PVDF TF - PTFE PP - Natural Polypro
<i>For other sizes, please consult factory.</i>				

PLAST-O-MATIC
VALVES, INC.

1384 Pompton Avenue, Cedar Grove, New Jersey 07009
(973) 256-3000 • Fax (973) 256-4745
www.plastomatic.com • info@plastomatic.com