

Series UPRS ULTRA-PURE PRESSURE REGULATORS INSTALLATION & MAINTENANCE INSTRUCTIONS IMPORTANT – BEFORE INSTALLING

Series UPRS Pressure Regulators will prevent downstream pressure from exceeding the set pressure, when properly installed and used within the recommended ranges of pressure, temperature, and chemical compatibility. The ultimate determination of material compatibility is previous successful use in the same application. See the Series UPRS Product Data Sheet or call our Technical Support for information about your application.

Caution:

1. Plastic materials will degrade in ultraviolet (UV) light or sunlight.
2. Polypropylene and PVDF (Kynar) look similar. Do not install if you are not sure.
3. Quick closing valves installed downstream of the regulator can cause water hammer. This may cause leakage, diaphragm or seal damage.

TABLE 1 - RATINGS AND SPECIFICATIONS

Set Pressure Range	10-100 PSI	0.69 to 7 Bar
--------------------	------------	---------------

TABLE 2 - MAXIMUM INLET PRESSURES FOR WATER*

Body Material	Color	77°F (25°C)	104°F (40°C)	At Maximum Temperature
Kynar	Translucent White	150 PSI	120 PSI	22.5 PSI@ 280°F
PVDF	Yellowish	10.3 Bar	8.27 Bar	1.5 Bar @ 140°C
PTFE	Opaque White	150 PSI 10.3 Bar	140 PSI 9.65 Bar	Consult Factory

or compatible chemical - ratings reduced for some applications. Minimum temperature 40°F (5°C).

INSTALLATION INSTRUCTIONS

Install the valve in the proper flow direction as indicated by the **flow arrow engraved on the valve body**. The valve may be mounted vertically or horizontally.

Spigot Connections – For heat fusion, follow the instructions supplied with the fusion equipment, or contact your distributor.

Mounting – The piping must be properly supported, taking into account the weight of the valve, piping, and process liquid. A bracket or shelf to support the valve must be used.

PRESSURE SETTINGS INSTRUCTIONS

Series UPRS pressure regulators sense downstream pressure; therefore it may be helpful to install a pressure gauge upstream and downstream of the regulator.

1. Install the regulator in the piping system. Close all downstream outlets to stop flow. The inlet pressure must be higher than the desired set pressure.
2. Loosen the pressure adjusting lock nut and set the pressure adjusting screw at the top of the regulator approximately half way in to start.
3. Slowly open the valve upstream of the regulator to let fluid into the system and not slam the regulator with a surge of pressure.
4. Adjust the set pressure only when the valve is pressurized. From the top looking down: clockwise (in) will increase set pressure, counterclockwise (out) will decrease the set pressure. If going from a high pressure setting to a lower set pressure, some fluid may have to be released from the downstream side of the regulator in order to let the downstream pressure drop.
5. When the desired set pressure is achieved and the unit is under pressure, retighten the adjusting screw lock nut. Do not overtighten.

CAUTIONARY NOTE:

If the system is to be shut down for a length of time, a valve upstream of the regulator should be closed and pressure downstream should be released. This will relieve stress on the regulator components when not in use.

MAINTENANCE

Plast-O-Matic recommends keeping a spare seal kit available for repairs. Seal life will vary in applications due to cycles, temperatures, pressures, chemicals, and concentration. Based on the application, a periodic inspection and maintenance plan should be established. The seal kit part number is "SK" plus the part number less the material suffix. For example, the seal kit for UPR050TPF-SO is SKUPR050TPF-SO.

TABLE 4 - PARTS LIST

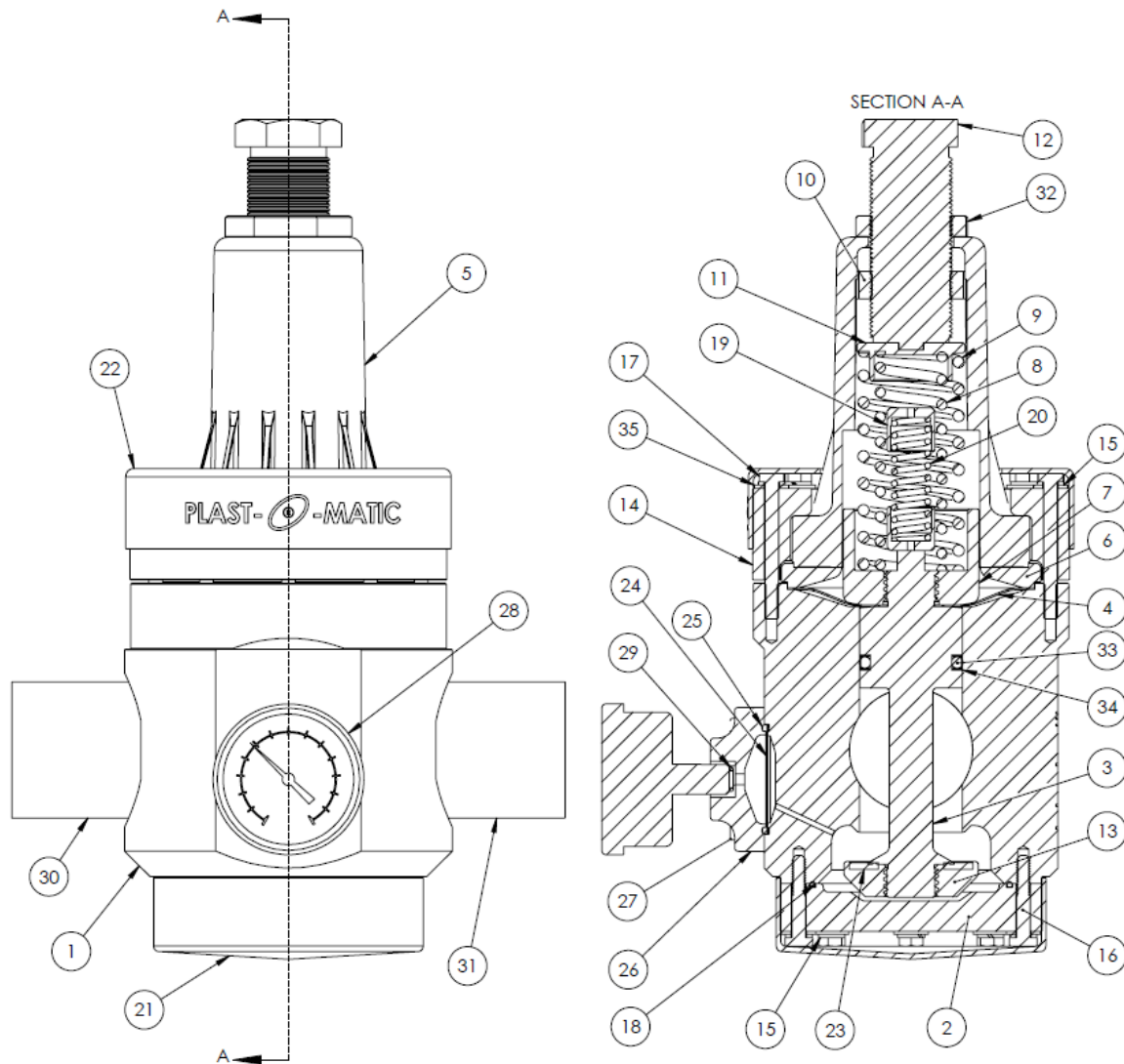

ITEM NO.	PART NUMBER	DESCRIPTION	QTY.
1	9948-02-PF	BODY W/GAGE L-R	1
2	9953-PF	BASE PLATE	1
3	9950-PF	SHAFT	1
4	10163	TFM DIAPHRAGM	1
5	8476-PF	SPRING HOUSING	1
6	8582-PF	DIAPHRAGM RING	1
7	9957-PF	SPRING RETAINER	1
8	8656	XYLAN COATED SS SPRING	1
9	8655	XYLAN COATED SS SPRING	1
10	8657-PF	THREADED ADAPTOR	1
11	8625-PF	SPRING GUIDE	1
12	8658-HDPE	ADJUSTING SCREW	1
13	9952-PF	SEAT RETAINER	1
14	10021-PF	CLAMP RING	1
15	F-LOC25N-S-C	SS / XYLAN LOCKWASHER, 1/4"	18
16	F-CSHH25C0150-S-C	XYLAN COATED SS SCREW 1/4-20 X 1-1/2"	8
17	F-TBHH25C250-S-C	XYLAN COATED SS TAP BOLT 1/4-20 X 2.5"	10
18	0153 FEP	FEP O-RING	1
19	10038-PF	SMALL SPRING SUPPORT	2
20	10039	XYLAN COATED SS SPRING	1
21	10037	VINYL BOTTOM CAP FOR UPR200	1
22	10019	UPRS 150-200 VINYL TOP CAP	1
23	10041-FFKM	FFKM SEAT GASKET	1
24	8621-PF	PVDF GAUGE GUARD DIAPHRAGM	1
25	0224V	VITON O_RING	1
26	7880-PF	GAUGE GUARD TOP	1
27	8617	XYLAN COATED SS SCREW	6
28	P160C-SS	SS PRESSURE GAUGE, CENTERBACK, 2.5" DIA	1
29	0011V	VITON O-RING	1
30	8485	SYGEF STRAIGHT SPIGOT	1
31	8486	SYGEF ANGELED SPIGOT	1
32	10040-HDPE	HDPE LOCK NUT	1
33	0325K	FFKM 0325 O-RING	1
34	GALE-21720	TFM PISTON CHANNEL SEAL	1
35	F-WUS25N-S-C	SS / XYLAN FLAT WASHER, 1/4"	18

Gauge version shown. List item numbers 24-29 not included on non-gauge guard version.