

Series "PRHM"

PRESSURE REGULATORS

Installation & Operating instructions

Installation

During installation be sure the flow through the valve is in the proper direction. All regulators are marked indicating the flow direction.

Plastic pipe threads should always be wrapped with Teflon• tape or other acceptable pipe sealant to effect a positive seal. The assembly need only be made hand-tight followed by a one-quarter turn more with a strap wrench. DO NOT overtighten or use a pipe wrench as future fracture could result.

NOTE: Threaded connections should never be made to metal piping.

A proper installation would include pressure gauges mounted up and downstream of the regulator. Plast-O-Matic gauge guards with gauges are suitable as they are designed specifically for corrosive or ultra-pure liquids.

Operation

A Plast-O-Matic pressure regulator prevents downstream pressure from exceeding the desired set pressure. The regulator is designed to remain closed as long as the set pressure (downstream) is maintained. As equipment downstream of the regulator begins to open and demand flow, the downstream pressure begins to fall and the regulator opens accordingly until its maximum opening is reached. (Check the flow capacity vs. pressure drop charts in Catalog PRHM to insure proper valve size selection.)

As the process is reversed, the downstream pressure begins to increase and the regulator starts closing when the pressure reaches the set pressure, the regulator closes.

NOTE: From the above explanation, a pressure regulator does not maintain a specific downstream pressure - it only prevents this pressure from exceeding the set point.

Caution! - Avoid quick shut offs of downstream equipment or valves as they transmit liquid shock waves with the possibility of damage to the regulator. If a valve must be closed quickly, install it before the regulator.

Pressure Setting

The Plast-O-Matic pressure regulator senses downstream pressure; therefore it is necessary to install a pressure gauge at the outlet of the regulator for setting.

1. All valves and equipment downstream of the regulator must be in the off position (no flow taking place).
2. System inlet pressure (maximum 150 PSI, 10 bars) is connected to the inlet of the regulator and the regulator outlet to the downstream piping containing a pressure gauge.
3. The pressure gauge at the regulator outlet will read the set pressure when the upstream pressure is turned on. If the pressure is too low, simply loosen the locking nut on the adjusting bolt and then screw the bolt down or into the spring housing until the desired set pressure is reached. Lock in the setting by tightening the nut.
4. If the pressure gauge reads too high, simply unscrew the adjusting bolt (back it away from the spring housing) until the desired pressure is reached. Open and close an outlet valve to bleed off a little liquid on the downstream side of the regulator to see if the set pressure remains the same. If not, adjust again. Then tighten the locking nut to lock in the setting.

Series "PRHM" PRESSURE REGULATOR

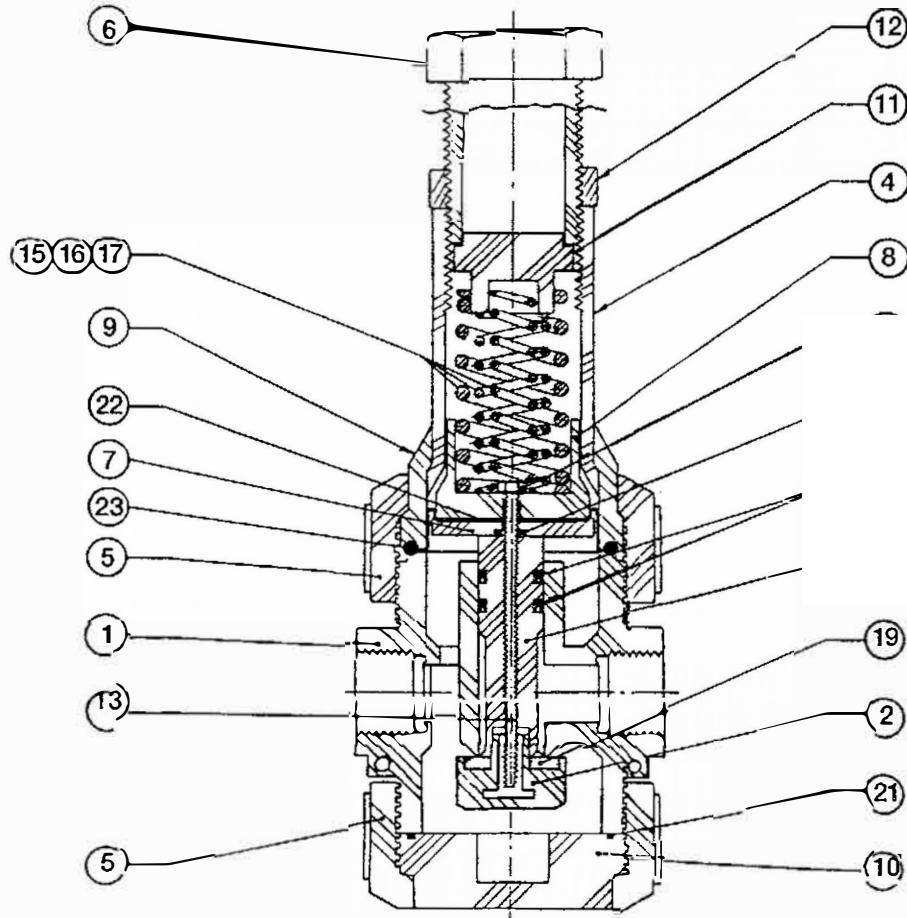

**IMPORTANT: SEAL MATERIAL MUST BE SPECIFIED
(FKM or EPDM)**

Caution! Quick shutoffs of downstream equipment or valves transmit liquid shock waves back to the regulator with the possibility of damaging it. It is best to close valves or equipment gradually to avoid these shocks. If a valve must be closed quickly, it is best to do so upstream of the regulator.

Series "PRHM" PRESSURE REGULATOR Parts List

ITEM	NAME
	BODY
1	SEAT RETAINER
2	SHAFT
3	SPRING HOUSING
4	NUT
5	ADJUSTING SCREW
6	DIAPHRAGM
7	RETAINER
8	PISTON
9	DIAPHRAGM HOUSING
10	BASE PLATE
11	SPRING GUIDE
12	LOCK NUT THREADED
13	ROD
14	NUT
15	SPRING
16	SPRING
17	SPRING
18	U-CUPS
19	SEAT GASKET
20	SHAFT O-RING BASE
21	O-RING
22	ROLLING DIAPHRAGM
23	TOP O-RING

PLASTOMATIC

1384 Pompton Avenue, Cedar Grove, NJ 07009
(973) 256-3000 • Fax: (973) 256-4745
www.plastomatic.com