

# SERIES "PR" & "PRH" – PRESSURE REGULATORS

## INSTALLATION & MAINTENANCE INSTRUCTIONS

### I. IMPORTANT – BEFORE INSTALLING

Series PR and PRH pressure regulators will prevent downstream pressure from exceeding the set pressure, when properly installed and used within the recommended ranges of pressure, temperature, and chemical compatibility. A Pressure Regulator *does not* maintain a specific downstream pressure if inlet pressure or flow is too low. The ultimate determination of material compatibility is previous successful use in the same application. See the Product Data Sheet or call our Technical Support for information about your application.

**Caution:** Quick closing valves installed downstream of the regulator may cause water hammer. This may cause leakage or seal damage. Plastic materials will degrade in ultraviolet (UV) light or sunlight. Polypropylene and PVDF (Kynar®) often look similar. Do not install in your system if you are not sure.

### II. PRESSURE RATINGS

#### A. Maximum Inlet Pressures for Water\*

Body Mat'l	Color	at		at Max. Temp.	
		77°F (25°C)	104°F (40°C)	PSI @ °F	Bar @ °C
PVC	Dk. Gray	150 PSI 10 Bar	106 PSI 7 Bar	34 @ 140°F	2 @ 60°C
CPVC	Lt. Gray	150 PSI 10 Bar	120 PSI 8 Bar	37 @ 180°F	2 @ 80°C
Polypro	Trans. Wht.	150 PSI 10 Bar	120 PSI 8 Bar	40 @ 180°F	2 @ 80°C
PVDF	Trans. Wht.	150 PSI 10 Bar	120 PSI 8 Bar	22 @ 280°F	1 @ 140°C
PTFE	Opaq. Wht.	150 PSI 10 Bar	140 PSI 10 Bar	Consult Factory	

\* or compatible chemical – ratings reduced for some applications Not rated for suction or vacuum. Min. Temperature 40°F (5°C). EPDM seals limited to 250°F (120°C), Buna-N to 200°F (95°C). See the Product Data Sheet or consult our Technical Support staff for more information.

**B. Set Pressure Range:** PR: 5-50 PSI (0.3 to 3 Bar)  
PRH: 30-125 PSI (2 to 8 Bar)

### III. INSTALLATION

Install the valve in the proper flow direction as indicated by the flow label. The valve may be positioned vertically or horizontally. Proper installation should include pressure gauges mounted upstream and downstream of the regulator for pressure setting and verification.

**Threaded Connections** – Apply a suitable thread sealant (for example, PTFE Tape) to male tapered threads to assure a "leak-tight" seal. Assemble "hand-tight" followed by a quarter (1/4) turn with a strap wrench. Do not over tighten or use pipe wrenches on plastic pipe and components.

**Caution:** PTFE tape will "string" as pipe threads are joined. Loose "strings" could lie across the seating surface and prevent the valve from completely closing. To avoid this problem, clean out old tape, and do not apply tape to the first thread.

**Caution:** Connect to plastic pipe and fittings only; when using metal pipe, install an intervening plastic fitting. Metal pipe and straight threaded pipe tends to cut, stretch, and distort the plastic bodies, resulting in cracking or leaking over time.

**Non-Threaded Connections** – For solvent cementing or heat fusion, follow the instructions supplied with the cement or fusion equipment, or contact your distributor.

**Mounting** – These valves are designed to be supported by the piping. The piping must be properly supported, taking into account the weight of the valve, piping and process liquid.

### IV. PRESSURE SETTING

Series PR and PRH sense downstream pressure; a pressure gauge should be installed at the outlet of the valve to accurately set the regulator. Downstream set pressure range is 10 to 125 PSI. The following procedure is for static (no flow) pressure setting. Under flow conditions, the outlet pressure may be slightly lower.

1. Install the regulator in the piping system. Close all downstream outlets to stop flow. The inlet pressure must be higher than the desired set pressure.
2. Loosen the locking nut on the adjusting screw assembly.
3. If the outlet pressure is too low, turn the screw clockwise (into the spring housing) until the set pressure is reached.
4. If the outlet pressure is too high, turn the screw counterclockwise (out of the spring housing) until the set pressure is reached. A downstream outlet valve must be opened to allow pressure to drop.
5. Tighten the locking nut to lock in the setting.

Pressure can also be set under dynamic (with flow) conditions using the same procedure. If pressure is set under dynamic conditions, outlet pressure will increase when downstream flow is reduced.

**Note:** Series PR and PRH True Blue Regulators are *non-relieving*. Outlet valves must be open to allow pressure to drop.

### V. MAINTENANCE

Plast-O-Matic recommends keeping a spare seal kit available for repairs. Seal life will vary in applications due to cycles, temperatures, pressures, chemicals, and concentration. Based on the application, a periodic inspection and maintenance plan should be established. The seal kit part number is "SK" plus the part number less the material suffix. For example, the seal kit for PR050V-PV is SKPR050V.

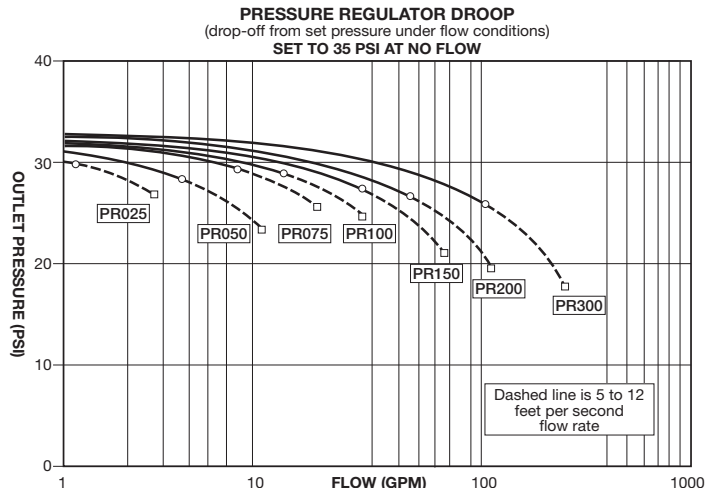

## PLAST-O-MATIC VALVES, INC.

1384 Pompton Avenue, Cedar Grove, NJ 07009 USA

(973) 256-3000 • Fax: (973) 256-4745 • www.plastomatic.com • info@plastomatic.com

SERIES "PR" & "PRH" INSTALLATION DATA SHEET SEE REVERSE SIDE FOR PARTS LISTS

# SERIES "PR" & "PRH" PRESSURE REGULATORS PARTS LIST

1/4" NPT

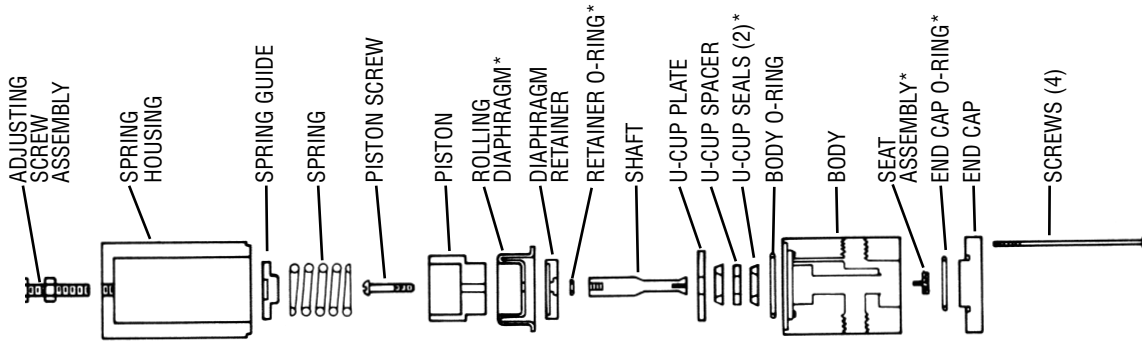

1/2" NPT

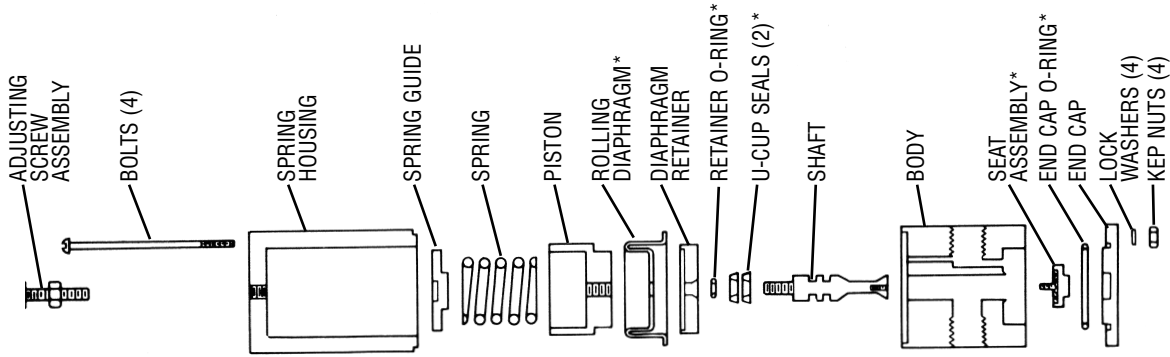

3/4", 1", & 1 1/2" NPT

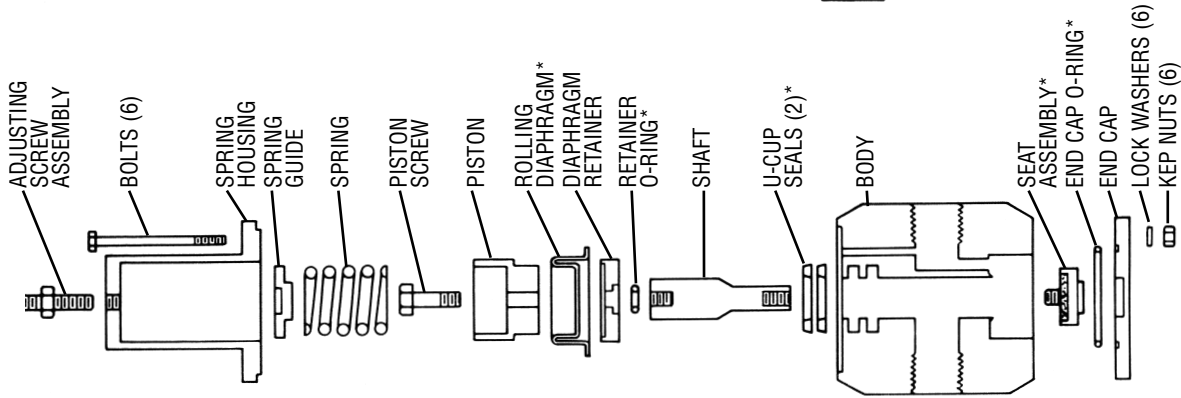

2" NPT

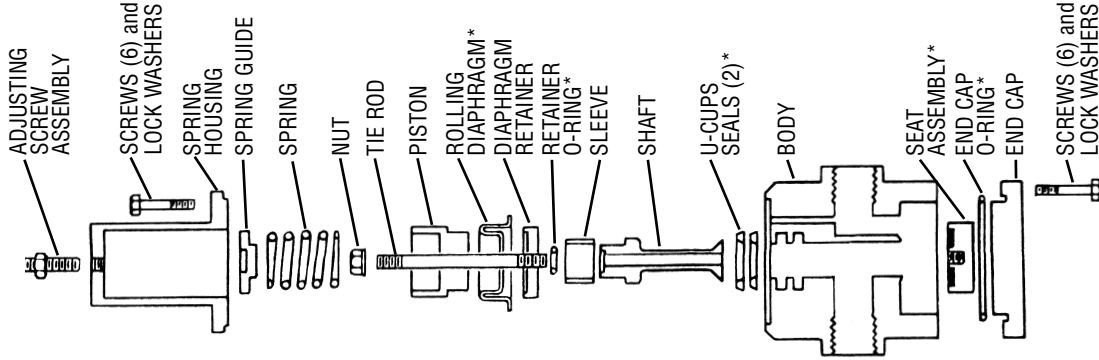

3" NPT

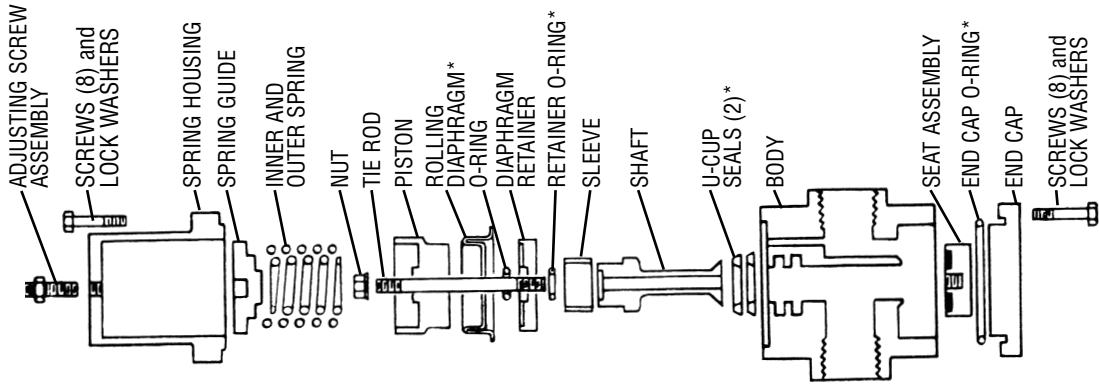

**PLASTOMATIC**

1384 Pompton Avenue, Cedar Grove, New Jersey 07009  
 (973) 256-3000 • Fax (973) 256-4745 • www.plastomatic.com

**\*IMPORTANT: SEAL MATERIAL MUST BE SPECIFIED (VITON, EPDM OR BUNA-N)**

**CAUTION!** Quick shut-off of downstream equipment or valves transmits liquid shock waves back to the regulator with the possibility of damaging it. It is best to close valves or equipment gradually to avoid these shocks. If a valve must be closed quickly it is best to do so upstream of the regulator.