

PLAST-O-MATIC BALL VALVE (MBV) SEAL KIT INSTRUCTIONS

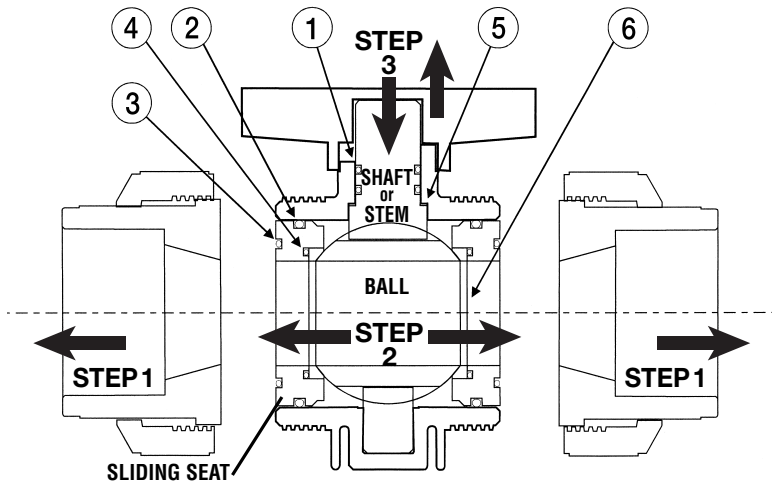

Item	Qty.	Description	Material
1	2	O-RING, SHAFT (or STEM)	FKM or EPDM as specified
2	2	O-RING, SLIDING SEAT	FKM or EPDM as specified
3	2	O-RING, END CONNECTOR	FKM or EPDM as specified
4	2	O-RING, BALL SEAT	FKM or EPDM as specified
5	1	THRUST WASHER	PTFE
6	2	PTFE SEAT	PTFE

- Before disassembly, relieve pressure and drain fluid from the valve and piping to be opened. Turn the handle part way to drain any liquid trapped in the valve body. Take proper precautions to protect people and equipment from any residual process liquid.
- Disassemble the valve in a clean environment. Prevent any dirt, grit, or fiber from getting onto the sealing surfaces or into the moving parts. Do not scratch or damage the plastic parts.
- A non-scratching probe such as an orangewood stick or ball or ball-end dental pick (burnisher) should be used to remove and install O-rings.
- Pipe wrenches and vises are not recommended for plastic valves.
- Refer to the ball valve instruction sheet for installation to piping.

STEP 1: Unscrew union nuts and remove end connectors.

STEP 2: Turn the handle to "OPEN" and use thumbs to push out sliding seats and ball; push or pull seats and ball out. Trunnion may fall out at this point; save and reinstall in bottom of valve body when reassembling. Trunnion must be oriented to accept ball slot.

STEP 3: Remove handle. Push down on stem and pull out through body.

FINAL STEP: Replace items 1 through 6 listed above, and reassemble; be sure to reinstall stem up through the valve body.

NEED HELP? Call 1-973-256-3000, fax to 1-973-256-4745,
or email to info@plastomatic.com, for Tech Support. Have valve model number ready.



PLAST-O-MATIC VALVES, INC.

1384 Pompton Avenue, Cedar Grove, New Jersey 07009 USA
(973) 256-3000 • Fax: (973) 256-4745 • www.plastomatic.com

mbvskim.pm5/ revised 9-28-99 WC/reprinted 2-23-01 RB / PTFE revised 2-23-06 / graphics REV 11-22